

Regrinding, Coating and Recoating Services

State-of-the-art CNC grinding and high performance Balzers BALINIT® thin film PVD coatings



Regrind Services

Solid carbide tooling is manufactured using micrograin carbide as standard, ground to a microfinish on state-of-the-art CNC grinding machines, and then surface coated in our Balzers PVD coating plant.

Somta also offers a cost effective value-add service of regrinding of any used carbide (or HSS) tooling, either standard or special form, to original specification and tolerances. This enables lower machining costs over the life of the solid carbide tool, with enhanced tool performance.

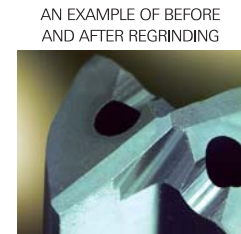
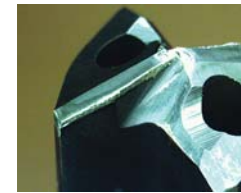

Coating and Recoating Services

Coupled to the solid carbide cutting tool regrind service, Somta also offers a recoating service, using its range of high performance Balzers BALINIT® thin film PVD coatings to further improve performance of original and reground carbide cutting tools.

Coating Technical Parameters

Product Name	Coating Material	Microhardness HV*	Friction Coef against steel (dry)*	Max Appl. Temp.*C	Coating Detail
BALINIT® A	TiN	2300	0.4	600	Gold-yellow monolayer
BALINIT® FUTURA NANO	TiAlN	3300	0.30-0.35	900	Violet-grey nanostructure
* BALINIT® XTREME	TiAlN	3500	0.4	800	Violet-grey monolayer

* supplied on request for volume applications

BALINIT® A (TiN)

A general purpose coating widely used for cutting and forming tools in a variety of industrial applications. Excellent for drilling. TiN coated solid carbide drills can be ordered on request. TiN coating is the standard coating on the HSS range, although due to higher solid carbide machining speeds, TiAlN coating is recommended for solid carbides.



BALINIT® FUTURA NANO (TiAlN)

A universal high-performance coating for drilling, milling, reaming and turning. Also suited to dry machining. Excellent for the most demanding machining applications. Features a remarkably tough multilayer structure. Futura Nano coated tools have increased metal removal rates with extended life under critical machining applications. Futura Nano TiAlN is the standard coating used for the solid carbide drill and end mill ranges.



BALINIT® X.TREME (TiAlN)

Best matched to solid carbide cutting tool substrate material for high demand high speed applications. XTREME is successfully employed under the extreme conditions of hard machining (45-65 HRc). Solid carbide milling cutters coated with XTREME typically permit much faster and more economical machining of dies. Available on request for solid carbide end mill volume applications.



FOR FURTHER TECHNICAL INFORMATION ON REGRINDING AND COATING SERVICES

Regrinding Services : Tel: +27 33 3556600 · Email : tech@somta.co.za

Coating Services : Tel: +27 33 3556633 · Email : coating@somta.co.za

Manufacturers & Suppliers

of Drills, Reamers, End Mills,

Bore Cutters,

Taps & Dies, Toolbits,

Custom Tools and

Surface Coatings



Head Office and Coating Division

Somta House, 290-294 Moses Mabhida Road, 3201
Private Bag X401, Pietermaritzburg 3200
South Africa

Tel: Factory: +27 33 3556600
Fax: Factory: +27 33 3940564
Tel: Sales: +27 33 3556798 (Local)
Fax: Sales: +27 33 3940564 (Local)
Tel: Sales: +27 33 3556600 (Exports)
Fax: Sales: +27 33 394 7509 (Exports)
Email: exports@somta.co.za

Technical Information:

Email: tech@somta.co.za
Toll Free Number: 0800-331-399

Gauteng Sales Office

43 Bisset Road, Hughes Ext. 7, Boksburg 1459
P.O. Box 14212, Witfield 1467
South Africa

Tel: +27 11 397 6696
Fax: +27 11 397 6720
Sharecall: 0860 104367
Email: jhbsales@somta.co.za

Gauteng Carbide Tools Division

Tel: +27 11 826 2576/836 2585
Fax: +27 11 826 5697
Email: tech@somta.co.za

Cape Town and Port Elizabeth Sales Office

Tel: +27 41 368 2060
Fax: +27 41 368 2060



www.somta.co.za



Solid Carbide Tooling for Optimised CNC Machining

Somta's 50 year history of producing high quality High Speed Steel (HSS) cutting tools, coupled with an investment in a state-of-the-art Balzers thin film coating plant means Somta world-class quality HSS coated cutting tool capabilities.

Now introducing Somta's next-generation tooling range... Somta Solid Carbide Cutting Tools - a comprehensive family of tungsten carbide stub and jobber length drills, 2 flute and multiflute end mills and ball nose end mills, in both regular and long series, and almost any special form carbide tooling.

This Somta carbide tooling range is manufactured from high grade micrograin tungsten carbide, with a physical vapour deposition (PVD) TiAlN coated and uncoated version as standard. A TiN coated option is available on request. For extremely high operating speeds, Balzers innovative XTREME coating is available for optimizing specialized applications.

This ultra high performance range of tooling is most suited to CNC applications, particularly when machining hard and abrasive materials, or when used on softer materials like fibreglass, brass and plastics.

The combination of solid tungsten carbide substrate with thin film PVD surface coatings, gives significant benefits with vastly improved cycle times on a broad range of work materials. Somta solid carbide tooling guarantees higher feed rates, superior surface finish and longer tool life, with the added value of local regrinding and recoating services.



S O L I D C A R B I D E T O O L I N G

Solid Tungsten Carbide

Drills



O1S
Solid Carbide Stub Drills
TAIN COATED (FUTURA NANO)

d	d1	l2	l1	DEPTH *	CODE
1	3	10	38	7	01S0100A
1.5	3	10	38	7	01S0150A
2	3	10	38	7	01S0200A
2.5	3	10	38	7	01S0250A
3	3	10	38	7	01S0300A
3.3	4	20	55	15	01S0330A
3.5	4	20	55	15	01S0350A
4	4	20	55	15	01S0400A
4.2	5	32	62	25	01S0420A
4.5	5	32	62	25	01S0450A
4.5	5	32	62	25	01S0500A
5.5	6	36	66	27	01S0650A
6	6	36	66	27	01S0600A
6.3	7	42	74	32	01S0630A
6.5	7	42	74	32	01S0650A
6.8	7	42	74	32	01S0680A
7	7	42	74	32	01S0700A
7.5	8	46	79	34	01S0750A
8	8	46	79	34	01S0800A
8.5	9	50	84	37	01S0850A
9	9	50	84	37	01S0900A
9.5	10	53	89	38	01S0950A
10	10	53	89	38	01S1000A
10.2	11	55	95	40	01S1020A
10.5	11	55	95	40	01S1050A
11	11	55	95	40	01S1100A
11.5	12	62	102	44	01S1150A
12	12	62	102	44	01S1200A
12.5	13	62	102	44	01S1250A
12.7	13	62	102	44	01S1270A
13	13	62	102	44	01S1300A
13.5	14	62	102	44	01S1350A
14	14	62	102	44	01S1400A

* Maximum drilling depth

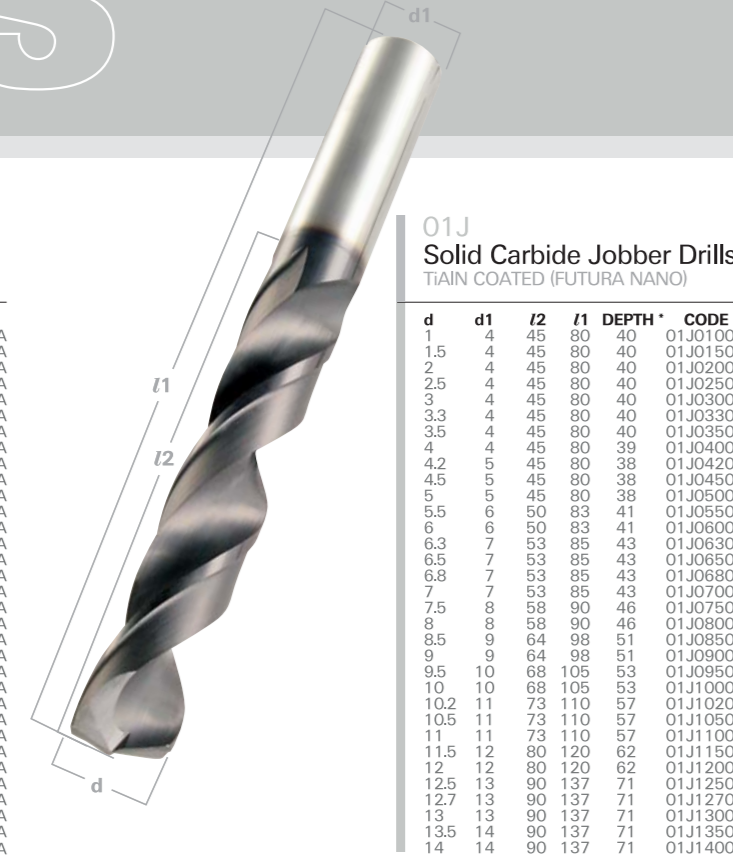

O1J
Solid Carbide Jobber Drills
TAIN COATED (FUTURA NANO)

d	d1	l2	l1	DEPTH *	CODE
1.5	4	45	80	40	01J0150A
2	4	45	80	40	01J0200A
2.5	4	45	80	40	01J0250A
3	4	45	80	40	01J0300A
3.3	4	45	80	40	01J0330A
3.5	4	45	80	40	01J0350A
4	4	45	80	39	01J0400A
4.2	5	45	80	38	01J0420A
4.5	5	45	80	38	01J0450A
5	5	45	80	38	01J0500A
5.5	6	50	83	41	01J0600A
6	6	50	83	41	01J0650A
6.3	7	53	85	43	01J0630A
6.5	7	53	85	43	01J0650A
6.8	7	53	85	43	01J0680A
7	7	53	85	43	01J0700A
7.5	8	58	90	46	01J0750A
8	8	58	90	46	01J0800A
8.5	9	64	98	51	01J0850A
9	9	64	98	51	01J0900A
9.5	10	68	105	53	01J0950A
10	10	68	105	53	01J1000A
10.2	11	73	110	57	01J1020A
10.5	11	73	110	57	01J1050A
11	11	73	110	57	01J1100A
11.5	12	80	120	62	01J1150A
12	12	80	120	62	01J1200A
12.5	13	90	137	71	01J1250A
12.7	13	90	137	71	01J1270A
13	13	90	137	71	01J1300A
13.5	14	90	137	71	01J1350A
14	14	90	137	71	01J1400A

* Maximum drilling depth

Solid Tungsten Carbide

End Mills



O3A
Solid Carbide 2 flute End Mills
TAIN COATED (FUTURA NANO)

d	l2	l1	d1	CODE
1	3	39	3	03A0100A
1.5	5	39	3	03A0150A
2	7	39	3	03A0200A
2.5	7	39	3	03A0250A
3	9	39	3	03A0300A
4	14	51	4	03A0400A
5	16	51	6	03A0500A
6	19	51	6	03A0600A
8	21	63	8	03A0800A
10	22	76	10	03A1000A
12	25	76	12	03A1200A
14	30	89	14	03A1400A
16	32	89	16	03A1600A
18	35	102	18	03A1800A
20	38	102	20	03A2000A
22	38	102	22	03A2200A
25	38	102	25	03A2500A

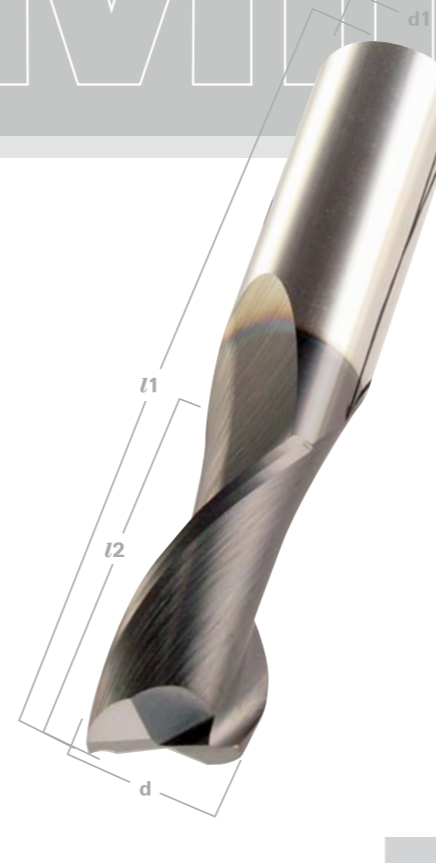

O3B
Solid Carbide 2 flute End Mills Long Series
TAIN COATED (FUTURA NANO)

d	l2	l1	d1	CODE
3	19	57	3	03B0300A
4	19	57	4	03B0400A
5	25	64	5	03B0500A
6	28	76	6	03B0600A
8	29	76	8	03B0800A
10	32	76	10	03B1000A
12	51	102	12	03B1200A
14	57	127	14	03B1400A
16	57	127	16	03B1600A
18	57	127	18	03B1800A
20	57	127	20	03B2000A
25	57	127	25	03B2500A



O3M
Solid Carbide 2 flute Ball Nose End Mills
TAIN COATED (FUTURA NANO)

d	l2	l1	d1	CODE
1	3	39	3	03M0100A
1.5	5	39	3	03M0150A
2	7	39	3	03M0200A
2.5	7	39	3	03M0250A
3	9	39	3	03M0300A
4	14	51	4	03M0400A
5	16	51	6	03M0500A
6	19	51	6	03M0600A
8	21	63	8	03M0800A
10	22	76	10	03M1000A
12	25	76	12	03M1200A
14	57	127	14	03M1400A
16	57	127	16	03M1600A
18	57	127	18	03M1800A
20	57	127	20	03M2000A
25	57	127	25	03M2500A

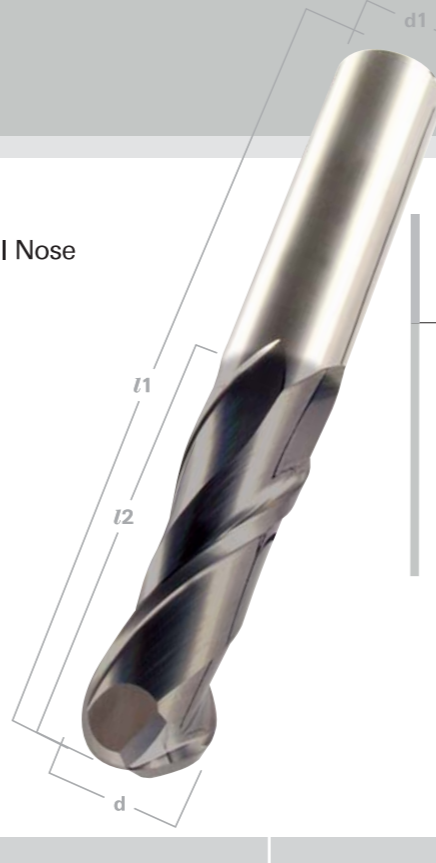

O3N
Solid Carbide 2 flute Ball Nose End Mills Long Series
TAIN COATED (FUTURA NANO)

d	l2	l1	d1	CODE
1	3	39	3	03N0300A
4	19	57	4	03N0400A
5	25	64	5	03N0500A
6	28	76	6	03N0600A
8	29	76	8	03N0800A
10	32	76	10	03N1000A
12	51	102	12	03N1200A
14	57	127	14	03N1400A
16	57	127	16	03N1600A
18	57	127	18	03N1800A
20	57	127	20	03N2000A
25	57	127	25	03N2500A



O3K
Solid Carbide Multiflute End Mills
TAIN COATED (FUTURA NANO)

d	l2	l1	d1	CODE
1	3	39	3	03K0100A
1.5	5	39	3	03K0150A
2	7	39	3	03K0200A
2.5	7	39	3	03K0250A
3	9	39	3	03K0300A
4	14	51	4	03K0400A
5	16	51	6	03K0500A
6	19	51	6	03K0600A
8	21	63	8	03K0800A
10	22	76	10	03K1000A
12	25	76	12	03K1200A
14	30	89	14	03K1400A
16	32	89	16	03K1600A
18	35	102	18	03K1800A
20	38	102	20	03K2000A
22	38	102	22	03K2200A
25	38	102	25	03K2500A

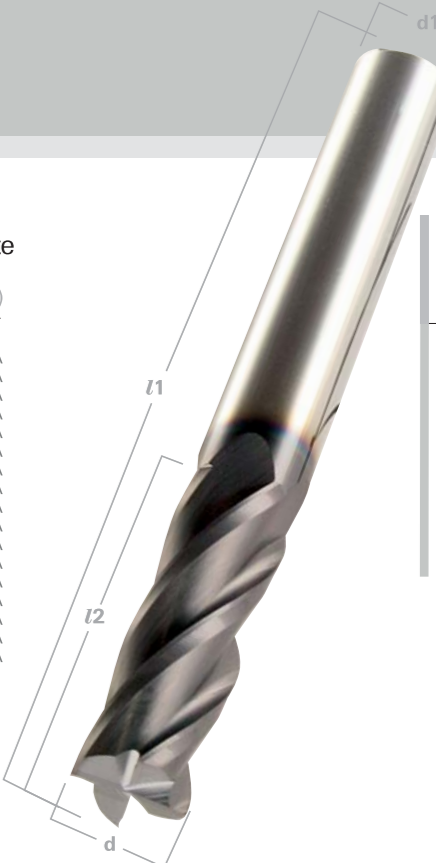

O3L
Solid Carbide Multiflute End Mills Long Series
TAIN COATED (FUTURA NANO)

d	l2	l1	d1	CODE
3	19	57	3	03L0300A
4	19	57	4	03L0400A
5	25	64	5	03L0500A
6	28	76	6	03L0600A
8	29	76	8	03L0800A
10	32	76	10	03L1000A
12	51	102	12	03L1200A
14	57	127	14	03L1400A
16	57	127	16	03L1600A
18	57	127	18	03L1800A
20	57	127	20	03L2000A
25	57	127	25	03L2500A

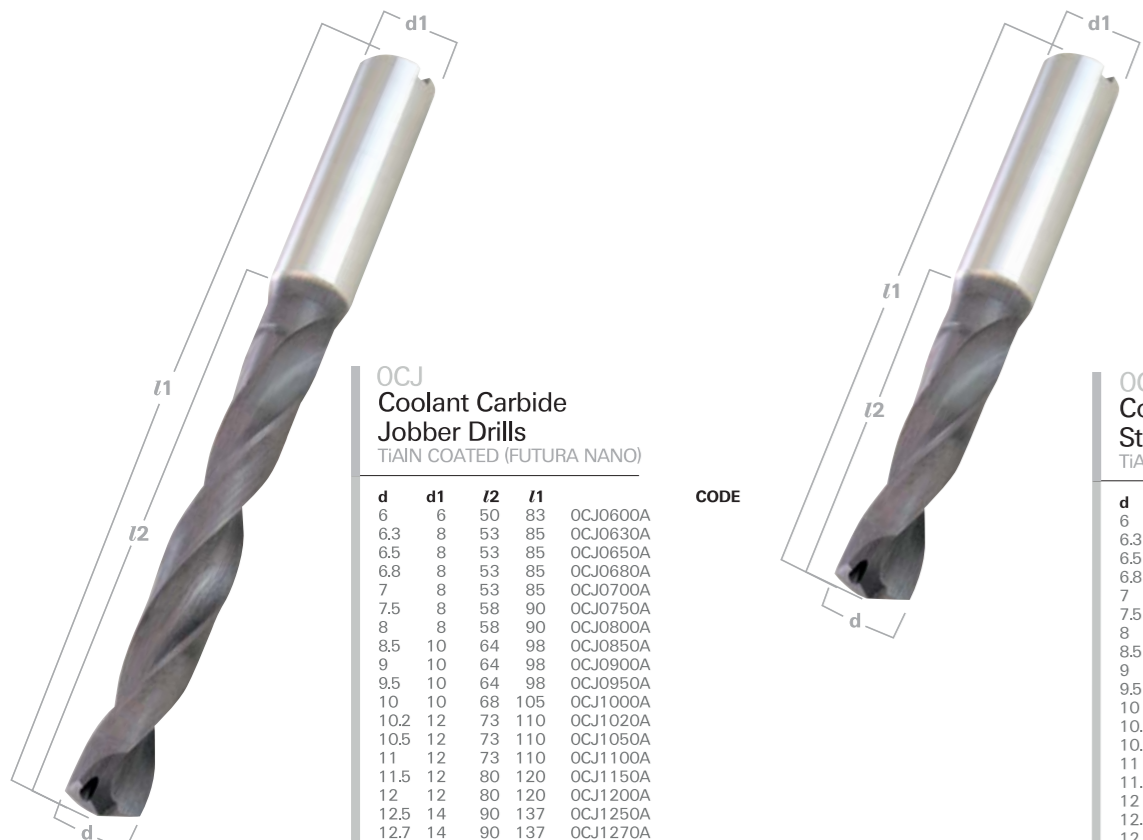

OCJ
Coolant Carbide Jobber Drills
TAIN COATED (FUTURA NANO)

d	d1	l2	l1	CODE
6	6	50	83	OCJ0600A
6.3	8	53	85	OCJ0630A
6.5	8	53	85	OCJ0650A
6.8	8	53	85	OCJ0680A
7	8	53	85	OCJ0700A
7.5	8	58	90	OCJ0750A
8	8	58	90	OCJ0800A
8.5	10	64	98	OCJ0850A
9	10	64	98	OCJ0900A
9.5	10	64	98	OCJ0950A
10	10	68	105	OCJ1000A
10.2	12	73	110	OCJ1020A
10.5	12	73	110	OCJ1050A
11	12	73	110	OCJ1100A
11.5	12	80	120	OCJ1150A
12	12	80	120	OCJ1200A
12.5	14	90	137	OCJ1250A
12.7	14	90	137	OCJ1270A
13	14	90	137	OCJ1300A
13.5	14	90	137	OCJ1350A
14	14	90	137	OCJ1400A

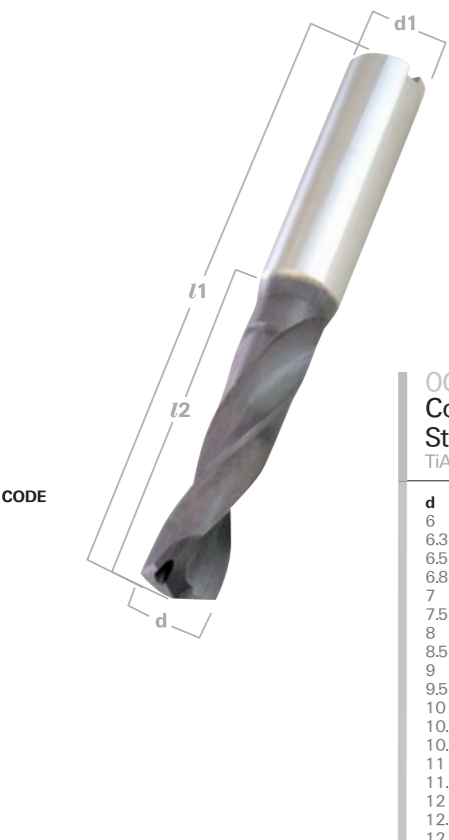

OCS
Coolant Carbide Stub Drills
TAIN COATED (FUTURA NANO)

d	d1	l2	l1	CODE
6	6	36	66	OCS0600A
6.3	8	42	74	OCS0630A
6.5	8	42	74	OCS0650A
6.8	8	42	74	OCS0680A
7	8	42	74	OCS0700A
7.5	8	46	79	OCS0750A
8	8	46	79	OCS0800A
8.5	10	50	84	OCS0850A
9	10	50	84	OCS0900A
9.5	10	50	84	OCS0950A
10	10	53	89	OCS1000A
10.2	12	55	95	OCS1020A
10.5	12	55	95	OCS1050A
11	12	55	95	OCS1100A
11.5	12	62	102	OCS1150A
12	12	62	102	OCS1200A
12.5	14	62	102	OCS1250A
12.7	14	62	102	OCS1270A
13	14	62	102	OCS1300A
13.5	14	62	102	OCS1350A
14	14	62	102	OCS1400A

Material Type	Grade	Hardness HB	Tensile Strength N/mm ²	Recommended Surface Speed in m/min for Coated Tungsten Carbide Drills		Recommended feed in mm per revolution for Coated Tungsten Carbide Drills														Recommended Surface Speed in m/min for Coated Tungsten Carbide End Mills		Recommended feed in mm per tooth for Coated Tungsten Carbide End Mills based on full diameter cutting width and half diameter cutting depth.									
				min	max	Drill Diameter in mm														min	max	End Mill Diameter in mm									
						1	2	3	4	5	6	8	10	12	13	14	16	2	4			6	8	10	12	16	20	25			
Steel	Free cutting steels Structural steel Plain carbon steel Alloy Steel Alloy steel, hardened and tempered steel	< 120 < 200 < 250 < 350 > 350	< 400 <																												